

NOTES

1. ALL INLET AND OUTLET PIPEWORK TO BE 6" PVCu.
2. OVERALL DIMENSIONS ONLY GIVEN.
3. UNIT MUST BE SLUNG IN POSITIONS SHOWN.

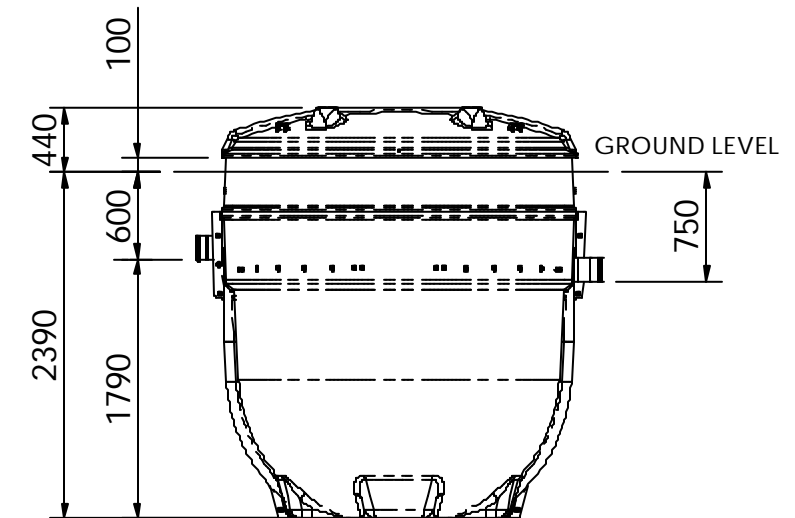

Title :  
BH - BL BIODISC  
GENERAL ARRANGEMENT

DWG No. : DS0721

Environmental Treatment Systems Limited  
reserve the right to alter the details  
of this drawing without prior notice.

Tolerance : ±10mm      Drawn By : RMT

Issue : A                      Date : 06.10.04

Please check with Environmental Treatment  
Systems Limited that this drawing is the latest issue.

Revised By :                      All dimension in MM

Date :                                  Scale at A3 : 1:50

College Road North, Aston Clinton,  
Aylesbury, Bucks, HP22 5EW  
Tel: 01296 633000